



net-line FW-5 micro telecontrol station



Outstanding performance in limited space

The net-line FW-5 RTU provides cost-effective solutions for telecontrol, station control and automation applications without compromising on quality and functionality. The compact field device in a stable DIN-rail housing contains all the components a high-performance system must provide for monitoring, control, archiving and transmission.

The capacity of the net-line FW-5 can be adjusted optimally to the conditions of your application by means of expansion modules for inputs and outputs (I/O) as well as for interface modules. Tailor-made solutions are made possible for virtually any task.

Typical applications

- Bay unit in transformer substations with link to protective equipment
- Intelligent secondary unit substation including earth fault and short circuit indicators in the outgoing feeders
- Control box for direct marketing of power
- Feed-in management in renewable energy plants
- Intelligent measurement point for wide area control in distribution networks
- Monitoring of infrastructure systems and pipe-bound media

net-line FW-5 overview

Small maintenance-free field device in micro-housing for DIN-rail mounting with 8 signals, 4 command outputs, 2 measurands. Ethernet LAN 10/100BaseTx, RS-485 and RS-232/V.24 interfaces for integration of communication drivers to IEC 61850, DNP3, IEC 60870-5-101/-104, -103, protective equipment, Modbus etc. PLC programming via IEC 61131-3. Configuration via LAN, USB-device, USB memory stick or SD card. Wide range power supply, 20 to 72 V DC.

Expansion with external modem modules e.g. SWT-12/SWT-96, M2G-1/GPRS, TETRA or dial-up modem. Expansion with up to 12 expansion modules.

net-line FW-5 hardware

The basic system can be expanded according to individual requirements and has impressive electric strength. It offers the following capacity and functions:

- 8 indication inputs
- 4 command outputs
- 2 measurand inputs, 16 bit, bipolar, multi-range
- Ethernet LAN TCP/IP
- RS-485 field interface
- RS-232/V.24 interface
- Integrated wide range power supply unit, 20 to 72 V DC
- Configuration via LAN, USB, memory stick or SD card
- Removable screw or spring-type terminals

net-line FW-5 software

The net-line FW-5 supports impressively fast setup and high level of compatibility thanks to the innovative and well-established setIT parameterisation software.

- Intuitive operator guidance
- Almost complete prevention of input errors
- Fault analysis by click and link to inaccurate entry
- Practical copy functions
- Context-sensitive online help
- Calculation and logic functions
- Extensive diagnostic features
- Integrated project documentation

The integrated soft PLC codeIT offers additional flexibility and allows many kinds of PLC programs to be implemented.



Communication routes

As with all the devices of the series5e products, the link to the control centre can be realised by many communication

routes and protocols directly or via master station, backed up with redundant systems if required.

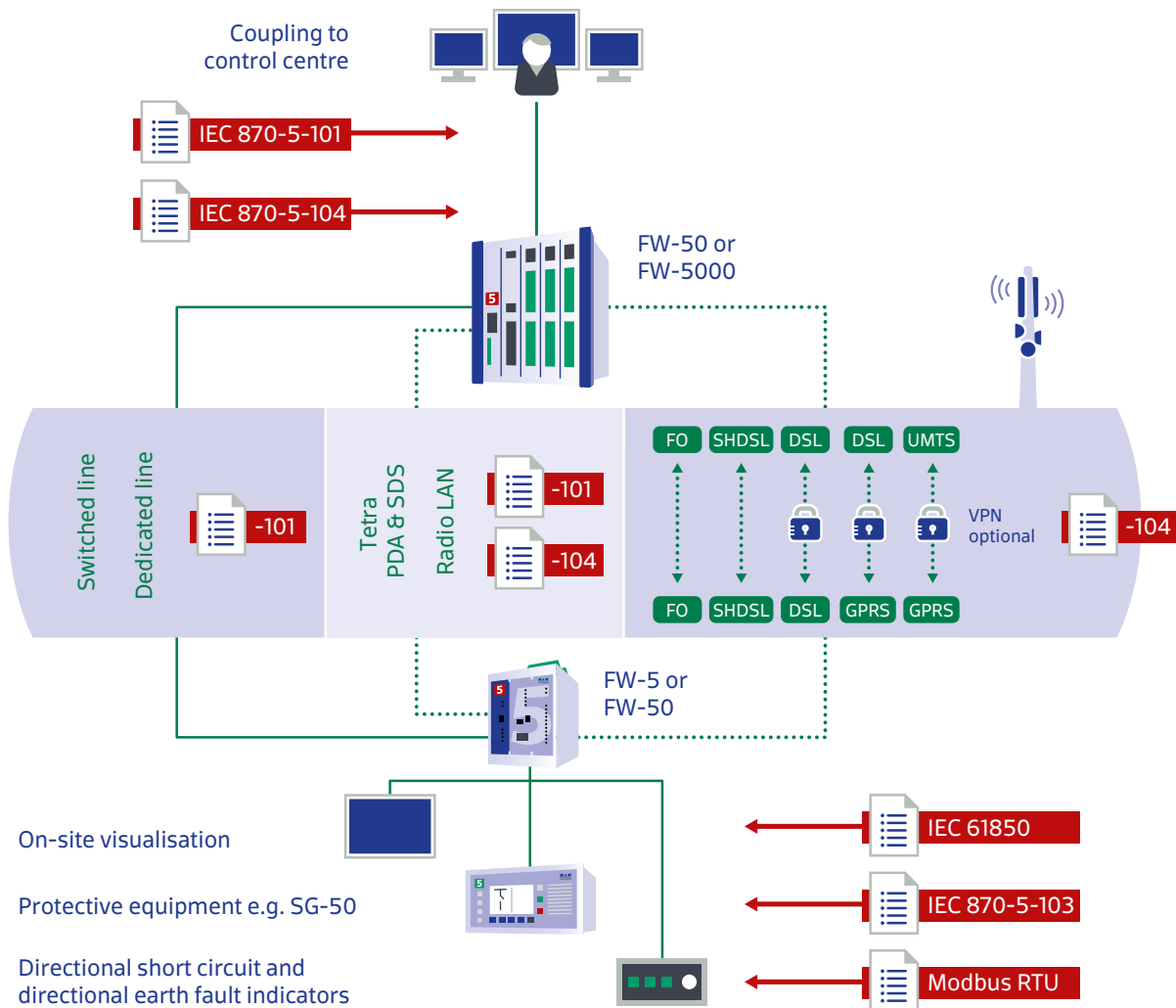

Technical data: net-line FW-5 series5e

Structure	Substation /bay control, telecontrol and automation system in plastic housing, integrated I/O, I/O expansion and communication modules, DIN rail mounting
Capacity base station	8 digital wide range inputs, 24 to 60 V DC $\pm 20\%$, optocoupler, common root; 4 relay NO contacts, 2-pole, up to 72 V DC, 150 V AC, isolated by channel 2 measurands, 16 bit, uni-/bipolar, overflow/underrun, multi-range mA
Communication	1 Ethernet LAN TCP/IP, 10/100BaseTx, auto-MDIX, auto-negotiation 1 EIA/RS-485 interface, isolated; 1 EIA/RS-232/V.24 interface
Input/output	Temperature sensor for ambient temperature, $-20\text{ }^{\circ}\text{C}$ to $100\text{ }^{\circ}\text{C}$ $\pm 2\text{ }^{\circ}\text{C}$ single-point, double-point, transformer tap position and alarm signals, measurands, metered values, single, double and transformer tap commands, set points, metered value pulse outputs, expandable up to 12 I/O modules
Protocols	IEC 61850 · IED and protective equipment IEC 60870-5-101 · telecontrol technology, station control technology IEC 60870-5-103 · protective equipment IEC 60870-5-104 · TCP/IP link to control centre DNP3 server · serial/IP IEC 62056-21 · smart meter link (former IEC 1107) SYM ² /SML · smart meter link via Ethernet DSfG · interface for natural gas equipment Modbus RTU/TCP · master/slave, Profibus-DP slave, MPI/3964R/RK512 · fieldbus SNMP · network management, NTP/SNTP/DCF clock synchronisation VPN-Tunnel · IPsec IKEv1/IKEv2, OpenVPN
PLC programming	IEC 61131-3 programming via codeIT, 128 kb program memory
CPU-5E series5e	RISC processor Cortex-A8, 1200 MIPS@800MHz, FPU, watchdog, real-time clock 1GB memory (512 MB SDRAM, 512 MB SLC Flash)
Memory expansion	SDHC card, up to 8 GB, 1 GB up to setIT V5
Real-time clock	Errors max. ± 20 ppm over entire temperature range, maintenance-free buffer, daylight saving time changeover, leap year correction
Status displays	LED in front panel for system, communication and binary process values detailed diagnostics via integrated web server
Operational controls	PLC switch in front panel RUN/STOP, USB pushbutton for configuration/backup/recovery functions
Programming interface	Ethernet LAN 10/100BaseTx, auto-MDIX, USB 2.0 device 12 Mbit/s, USB 2.0 host 12 Mbit/s (configuration/archive synchronisation via stick)
Fault signal output	To be configured to relay output, parameterisable sys-LED
Power supply	+20 to 72 V DC max. 5 W, (24 V DC 0.2 A/60 V DC 0.1 A) without expansion; Power fail management with mains buffering
Dielectric strength	5 kV surge supply and process I/O to PE, according to class VW3 2.5 kV surge, supply to measurands, EIA/RS-232, USB
Standards	EMC: EN61000-6-2 (03/2000), EN61000-6-4 (03/2000), EN55022, Insulation: DIN EN 60870-2-1, IEC 60255-5 R&TTE: ETSI EN 300328, EN 301489, NSRL: DIN EN 60950
Housing	FW-5 Micro, polyamide V0, IP20, weight 360 g dimensions FW-5: 68×105×115 mm (W×H×D); expansions: 22.5×105×115 mm
Installation	DIN rail mounting, DIN-EN 60715 TH35
Terminals	MSTB removable screw-type terminal or spring terminal, 0.2 - 2.5 mm ²
Ambience	-25° to $+70^{\circ}\text{C}$, $\varnothing 24\text{h}$ max. $+55^{\circ}\text{C}$, from 48V DC or 5 expansion modules: max $+60^{\circ}\text{C}$ humidity < 95%, without condensation

Overview of the expansion modules

The net-line FW-5 can be extended with up to 12 expansion modules. Various modules with different capacities at inputs/outputs allow flexible process integration which meets your requirements. With the TBUS-T and TBUS-R accessories, the EUs can also be placed remotely from the base system. For higher power supply requirements, above the capacities of the basic unit, the power supply module PWR-1 can be added. All modules have the dimensions of 22.5 × 105 × 115 mm (W×H×D).

Signals and commands

8DO 8 commands
8DI 8 signals
8DI2AI 8 signals, 2 measurands

Measurands and set points

4AI 4 measurands
2AO 2 set points
4AO 4 set points

Modules for special tasks

4DI4DO 4 signals, 4 measurands
RES-1 4 SO pulse inputs, 2 measurands, 4 commands
VPP-1* 6 signals, 2 measurands, 5 commands, 2 set points
PM-1 Power measurement terminal
ISO-1* Leakage detection

Command termination

DSO-1 6 commands, 6 check-back signals
DSO-2 4 commands, 2 check-back signals

Online

PDPS-1 Profibus-DP slave
M2G-1 GPRS/EDGE Modem

Other accessories

PWR-1 Power booster with larger capacities
TBUS-T T-BUS extension transmitter
TBUS-R T-BUS extension receiver

Product variants & accessories

FW-5

FW-5 base unit

FW-5-GATE

Variant without integrated I/O on the base unit with 2nd Ethernet interface and additional interface for smart meter read out

FW-5-GATE-4G

Variant without integrated I/O on the base unit with 2nd Ethernet interface and additional interface for smart meter read out
4G/LTE mobile router

FW-5-GATE-450

Variant without integrated I/O on the base unit with 2nd Ethernet interface and additional interface for smart meter read out
450 MHz CDMA radio module

mcPS-1

Power supply module for
Media converter
24 to 60V DC ± 20%

mcFO

Media converter FO coupler with
ST or SC connector



SAE IT-systems GmbH & Co. KG
Im Gewerbegebiet Pesch 14
50767 Cologne (Germany)
Phone: +49 221/59808-0
Fax: +49 221/59808-60
info@sae-it.com
www.sae-it.com